

apleton

Papagiannopoulos Bros

timbre



LUMINAIRE DESCRIPTION

Timbre is a custom-made product, designed especially for hotel doors since it can illuminate the number, it works as a bell and it can host any notification.

The fitting is composed of three elements, wall mounted plate made by inox, spot light made by bronze and clip for hanging notifications made by inox.

LUMINAIRE DRAWING

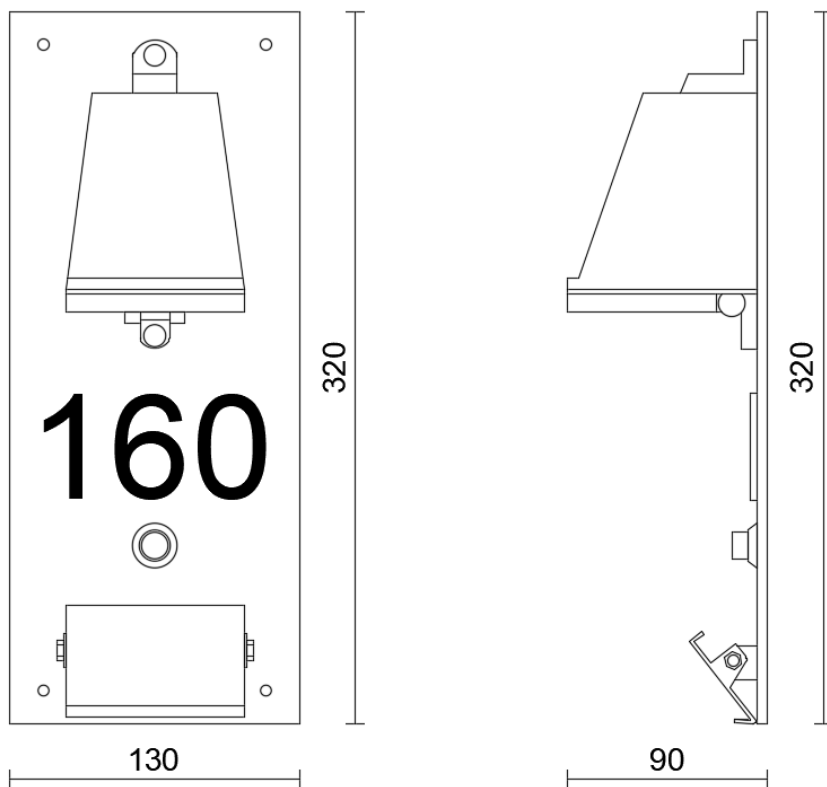

LUMINAIRE INFORMATION

Product Name: timbre

Code: -

Environment Application: indoor / outdoor

Driver: n/a

LUMINAIRE DETAILS

Fitting Type: wall mounted

Plate Material: inox

Spot Material: bronze

Clip Material: inox

Dimensions: W/ H / L upon request

Adjustability Angle: n/a

Rotation Angle: n/a

IP Rating: 65 or more

LIGHT SOURCE

Type: LED

Socket: GU 10

Voltage: 230V

Wattage: 5W